

Learn More

FASTfluidic FilterProbe: Ultra-high Throughput for Determination of Gold in Ore-grade Samples by ICPOES

Synopsis

FASTfluidic is a fourth generation ICP valve injection system with syringe backflushed CTFE FilterProbe that delivers 1000-fold Au rinseout in seconds. The automated system includes a RidingRinse autosampler with rinse station access in <0.5 s, eliminating translation time between samples. Sample throughput for 1000-fold Au rinseout

is >270 samples per hour. At 500-fold Au rinseout, throughput is 360 samples per hour. FASTfluidic FilterProbe reduces maintenance, prevents valve clogs, improves rinseout, increases instrument up-time, and delivers clean baselines between samples to provide productivity gains needed for ore-grade gold analyses.

FASTfluidic FilterProbe Key Features and Benefits

- 13 s sample-to-sample for 1000x Au rinseout (0.1%)
- Syringe-driven 5% HCl Rinse
 - 1.5 mL of rinse in <1 second
- Backflushing CTFE FilterProbe prevents clogs
- RidingRinse Accessed in <0.5 seconds

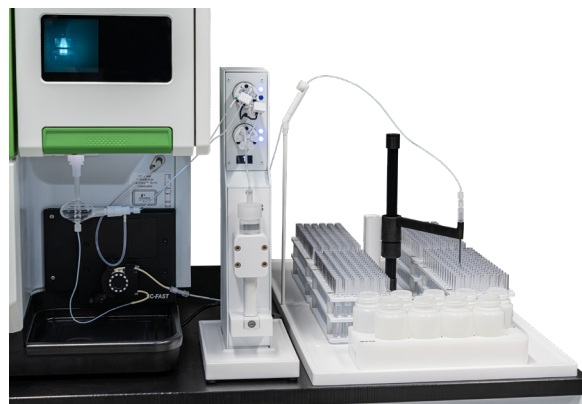

Figure 1. FASTfluidic FilterProbe configured for analysis with an Avio 550 Max.

Instrumentation

FilterProbe with Syringe-driven Backflush

The FilterProbe's inline CTFE filter prevents particulates, fibers and debris from entering the sample flowpath, significantly reducing valve and nebulizer maintenance. The free-flowing filter enables unrestricted sample transport without slowing analytical runs, while syringe-driven backflushing automatically clears the sample flowpath before the next sample is analyzed.

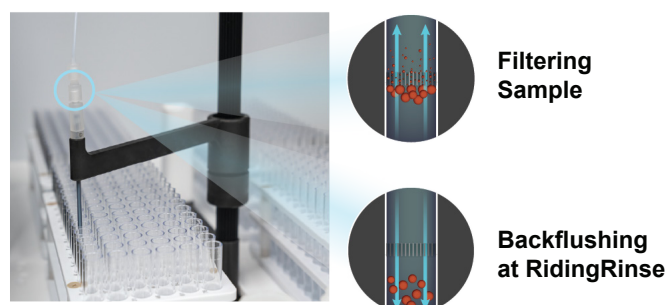

Figure 2. FilterProbe catches particulates and backflushes them to waste.

RidingRinse: Mobile Rinse Station

RidingRinse moves with the autosampler carriage, providing the fastest access to a rinse station and further expediting sample-to-sample time. With a simple rotary movement, FASTfluidic FilterProbe can perform backflushing and rinsing in place, preventing wasted autosampler movements required for a conventional fixed rinse location.



Figure 3. RidingRinse integrated to 4DXW autosampler.

Multiposition Magnetic SnapValves

FASTfluidic FilterProbe features patented Magnetic SnapValves with magnetic coupling technology, enabling valves to snap on and off by hand for tool-free installation and maintenance. Clearly labeled ports simplify line attachment, and cleaning takes just seconds, enhancing both usability and efficiency.

SampleSense 3

SampleSense 3 Optical Sensors are integrated into the sample flowpath, providing intelligent, real-time sample detection that automatically triggers analysis. This eliminates fixed timing parameters, improving throughput and reducing sample consumption. It adapts dynamically to variable sample viscosities and detects missed or incomplete samples, delivering real-time error notifications.

4DXW Autosampler

The innovative 4DXW autosampler increases sample capacity by 55% in a footprint narrower than a conventional 4-rack autosampler.

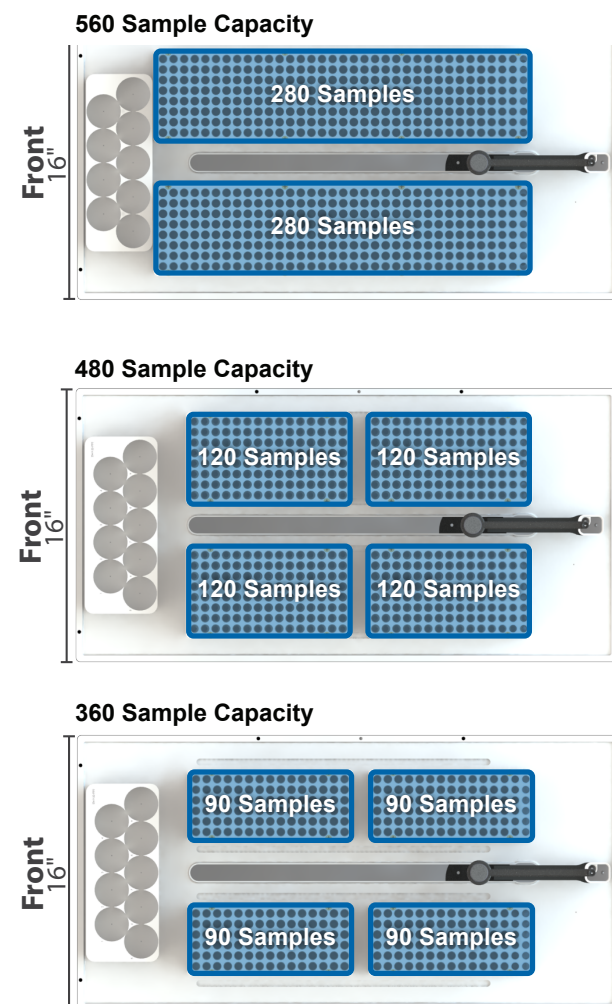

Figure 4. 4DXW autosampler example rack layouts. Capacities up to 560 samples taking up only 16" of linear lab bench space.

Experimental

Table 1. Instrument Conditions 1000x Washout Method.

Instrument Parameter	Value
Instrument	Avio 550 Max
Peri-Pump Rate	1.5 mL/min
Matrix	5% HCl
Axial Acquisition View	15 mm
Plasma Gas Flow	12 L/min
Auxiliary Gas Flow	0.5 L/min
Nebulizer Gas Flow	0.55 L/min
RF Power	1500 Watts
Integration Time	3 Seconds
Replicates	2
Total Measurement Time	6 Seconds
Total Time Sample-to-Sample	13 Seconds

Table 2. Sample Introduction Parameters.

Sample Introduction Parameter	Value
FAST System	FASTfluidic FilterProbe
Filter	FilterProbe CTFE Filter
Autosampler	ESI 4DXW with RidingRinse
Nebulizer	PFA ST3 Nebulizer
Spray Chamber	G3 Cyclonic
Injector/Torch	2 mm Quartz ZipTorch
Sample Tubing	Black-Black
ISTD Tubing	Orange-Green
Backflush Syringe	HPQ-24 mL

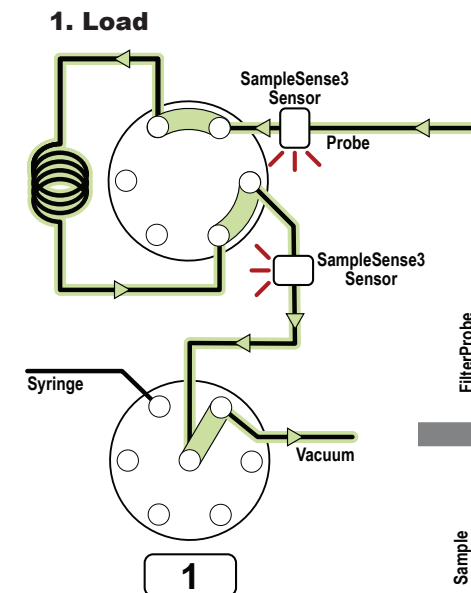

Figure 5. Free-flowing filtered sample loaded to valve loop with SampleSense3 detection.

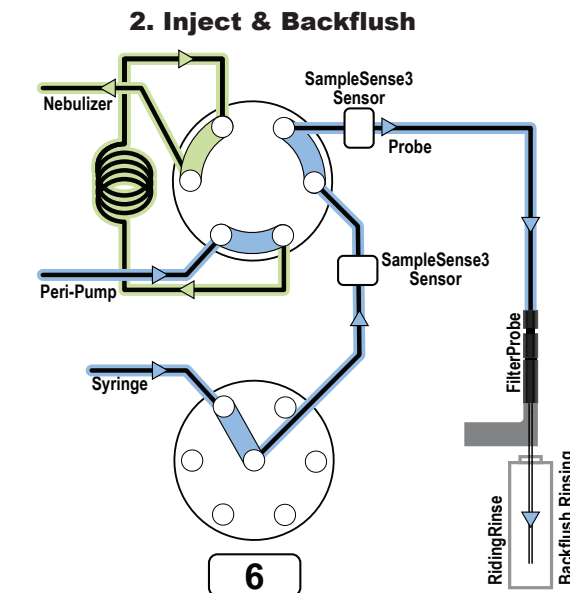

Figure 6. Sample injected and analyzed while FilterProbe is backflushed and rinsed.

Sample Throughput and Rinseout

Sample-to-Sample Time

	Sample Id	Acquisition Time	Au 242.795 (cps)	Au 267.595 (cps)	Tm 313.1... (cps)
1	1ppm	2/23/2026 11:22:31 AM	11398.6	7896.8	176117.9
2	1ppm	2/23/2026 11:22:43 AM	11393.8	7926.9	176926.6
3	1ppm	2/23/2026 11:22:55 AM	11268.3	7871.7	174896.6
4	1ppm	2/23/2026 11:23:08 AM	11389.3	7805.0	178916.1
5	1ppm	2/23/2026 11:23:20 AM	11492.6	7936.6	177382.8
6	1ppm	2/23/2026 11:23:32 AM	11640.8	8001.6	179724.9
7	1ppm	2/23/2026 11:23:45 AM	11465.4	7870.2	178867.0
8	1ppm	2/23/2026 11:23:57 AM	11556.9	7899.3	179073.8
9	1ppm	2/23/2026 11:24:09 AM	11625.2	7934.6	180765.2
10	1ppm	2/23/2026 11:25:11 AM	11638.4	7906.2	180188.6

Figure 7. Sample-to-sample analysis of 1 ppm Au in 13 seconds or less.

Rinseout

Table 3. Au rinseout factors for several analytical conditions. Methods are easily adjusted to effect maximum throughput for the desired rinseout factor. The backflushing syringe delivers 1.5 ml of 5% HCl rinse in less than 1 second, effecting superior rinseout performance for Au compared with much slower peristaltic pump rinseout for each analytical condition.

Condition	Sample-to-Sample Time (s)	Samples per Hour	Total ICP Integration Time (s)	Au Rinseout Factor
1 s Syringe Backflush	10	360	3	500x
1 s Syringe Backflush	13	275	6	1000x
1 s Syringe Backflush + Loop Rinse	18	200	6	5000x

	Sample Id	Acquisition Time	Au 242.795 (cps)
1	Blank	2/23/2026 12:21:15 PM	22.4
2	Blank	2/23/2026 12:21:33 PM	19.4
3	Blank	2/23/2026 12:21:51 PM	31.2
4	Blank	2/23/2026 12:22:09 PM	6.7
5	Blank	2/23/2026 12:22:28 PM	-4.0
6	100ppm	2/23/2026 12:22:46 PM	1075989.8
7	100ppm	2/23/2026 12:23:04 PM	1068599.5
8	100ppm	2/23/2026 12:23:22 PM	1075418.8
9	Blank	2/23/2026 12:23:40 PM	195.7
10	Blank	2/23/2026 12:23:59 PM	27.6
11	Blank	2/23/2026 12:24:17 PM	10.9
12	Blank	2/23/2026 12:24:35 PM	-16.0
13	Blank	2/23/2026 12:24:54 PM	-4.4

Figure 8. Rinseout of 100 ppm Au using an 18-second syringe-backflush method. The net signal for 100 ppm Au is 1 million cps. The first 5% HCl blank analyzed after 100 ppm Au is 200 cps above the initial blank demonstrating a rinseout factor of 5000x.

Calibration Linearity for Two Au Lines

Linearity

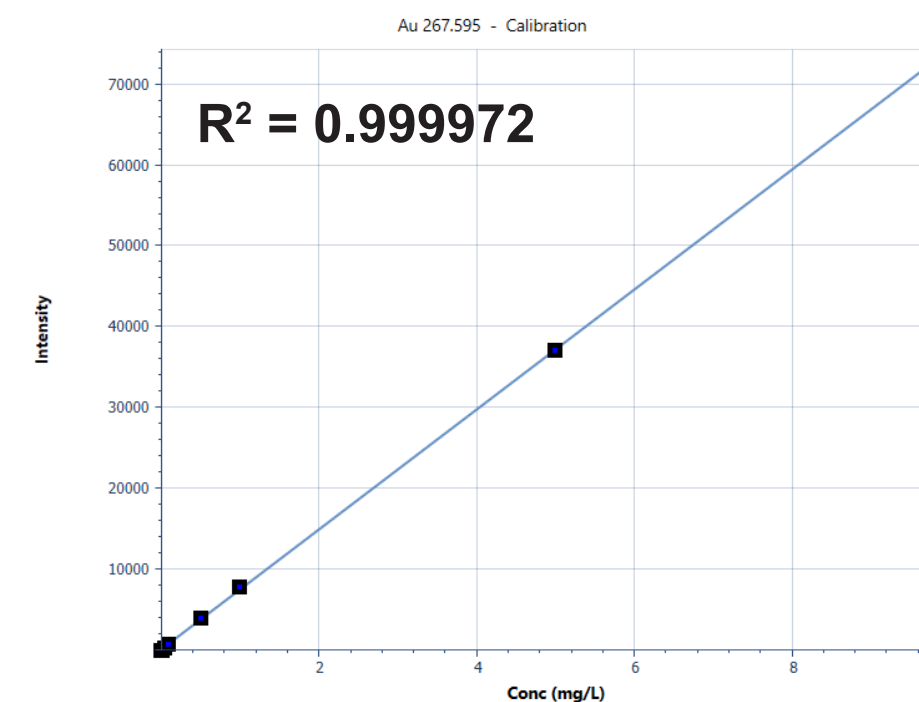
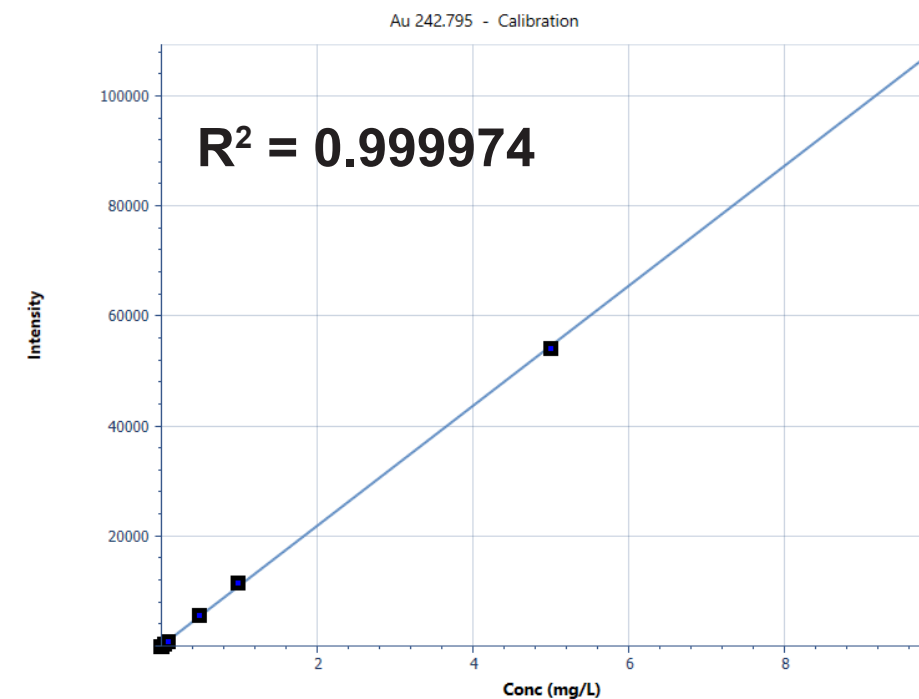

Figure 9. Au calibration curves in ~1 minute with R^2 of >0.9999.



© Elemental Scientific | 7277 World Communications Drive | Omaha, NE 68122
Tel: 1-402-991-7800 | sales@icpms.com | www.icpms.com

A-26058